



## Terreal

UK Customer Service  
 P O Box 259  
 Twickenham  
 Middlesex TW2 5ZX  
 Tel: 020 8893 8609 Fax: 020 8893 8643  
 e-mail: facade@terreal.co.uk  
 website: www.terreal.co.uk

(41)	Rnó
------	-----

**Agrément  
 Certificate  
 No 06/4298**

Designated by Government  
 to issue  
 European Technical  
 Approvals

## ZEPHIR CLADDING SYSTEM

Panneaux de façade  
 Verkleidungsplatten

# Product



• THIS CERTIFICATE OF CONFIRMATION RELATES TO THE ZEPHIR CLADDING SYSTEM.

• The system is an open-jointed, back ventilated and drained cladding, comprising terracotta tiles hung on aluminium support rails.

• It is essential that the cladding is installed in accordance with the manufacturer's instructions and the requirements of this Certificate.

## Regulations

### 1 The Building Regulations 2000 (as amended) (England and Wales)

 The Secretary of State has agreed with the British Board of Agrément the requirements of the Building Regulations to which cladding products can contribute in achieving compliance. In the opinion of the BBA, the Zephir Cladding System, if used in accordance with the provisions of this Certificate, will meet or contribute to meeting the relevant requirements.

Requirement: <b>A1</b>	Loading
Comment:	The system is acceptable for use as set out in sections 7.2 and 9.1 to 9.6 of this Certificate.
Requirement: <b>B4(1)</b>	External fire spread
Comment:	The system is judged to meet the Class 0 requirements. See sections 10.1 to 10.5 of this Certificate.
Requirement: <b>C2(b)(c)</b>	Resistance to moisture
Comment:	The system is not watertight but, when installed in accordance with this Certificate, will resist the passage of rain-water to the supporting structure. See sections 11.1 to 11.6 of this Certificate.
Requirement: <b>Regulation 7</b>	Materials and workmanship
Comment:	The system is acceptable. See sections 13.1 to 13.3 of this Certificate.

continued

continued

• The system is manufactured by Terreal and distributed in the UK by:  
 Terreal UK Marketing Office  
 P O Box 259  
 Twickenham  
 Middlesex TW2 5ZX  
 Tel: 020 8893 8609  
 Fax: 020 8893 8643  
 e-mail: [facades@terreal.co.uk](mailto:facades@terreal.co.uk)

Confirmation of a French  
 Technical Approval 2/02-971  
 issued by Centre Scientifique et  
 Technique Bâtiment (CSTB), to  
 Terreal.

# Electronic Copy

## 2 The Building (Scotland) Regulations 2004



In the opinion of the BBA, the Zephir Cladding System, if used in accordance with the provisions of this Certificate, will satisfy or contribute to satisfying the various Regulations and related Mandatory Standards as listed below.

Regulation:	8	Fitness and durability of materials and workmanship
Regulation:	8(1)	Fitness and durability of materials and workmanship
Comment:		The system can contribute to a construction satisfying this Regulation. See sections 13.1 to 13.3 and the <i>Installation</i> part of this Certificate.
Regulation:	8(2)	Fitness and durability of materials and workmanship
Comment:		The system can comply. See sections 13.1 to 13.3 and the <i>Installation</i> part of this Certificate.
Regulation:	9	<b>Building standards — construction</b>
Standard:	1.1(a)(b)	Structure
Comment:		The system is acceptable, with reference to clause 1.1.1 <sup>(1)(2)</sup> . See sections 7.2 and 9.1 to 9.6 of this Certificate.
Standard:	2.6	Spread to neighbouring buildings
Comment:		The system can contribute to satisfying this Standard with reference to clause 2.6.4 <sup>(1)(2)</sup> . See sections 10.1 to 10.5 of this Certificate.
Standard:	2.7	Spread on external walls
Comment:		The system can contribute to satisfying this Standard with reference to clause 2.7.1 <sup>(1)(2)</sup> . See sections 10.1 to 10.5 of this Certificate.
Standard:	3.10	Precipitation
Comment:		The system is not watertight but will resist the passage of rainwater to the supporting structure, with reference to clauses 3.10.1 <sup>(1)(2)</sup> to 3.10.3 <sup>(1)(2)</sup> . See sections 11.1 to 11.6 of this Certificate.
		(1) Technical Handbook (Domestic).
		(2) Technical Handbook (Non-Domestic).

## 3 The Building Regulations (Northern Ireland) 2000



In the opinion of the BBA, the Zephir Cladding System, if used in accordance with the provisions of this Certificate, will satisfy or contribute to satisfying the various Building Regulations as listed below.

Regulation:	B2	Fitness of materials and workmanship
Comment:		The system is acceptable. See sections 13.1 to 13.3 of this Certificate.
Regulation:	C4	Resistance to ground moisture and weather
Comment:		The system is not watertight but will resist the passage of rainwater to the supporting structure. See sections 11.1 to 11.6 of this Certificate.
Regulation:	D1	Stability
Comment:		The system is acceptable as set out in sections 7.2 and 9.1 to 9.6 of this Certificate.
Regulation:	E5	External fire spread
Comment:		The system is judged to meet the Class 0 requirements. See sections 10.1 to 10.5 of this Certificate.

## 4 Construction (Design and Management) Regulations 1994 (as amended) Construction (Design and Management) Regulations (Northern Ireland) 1995 (as amended)

Information in this Certificate may assist the client, planning supervisor, designer and contractors to address their obligations under these Regulations.

See section: *6 Delivery and site handling (6.5 and 6.6).*

## Technical Specification

### 5 Description

5.1 The Zephir Cladding System is an open-jointed, back ventilated and drained system comprising terracotta tiles hung on horizontal aluminium support rails (see Figure 1).

5.2 The terracotta tiles are of one basic design with nominal sizes 605 mm by 300 mm by

14 mm thick and 300 mm by 300 mm by 14 mm thick (see Figure 1). Ribs at tile edges can be removed on site to allow corner details to be formed.

5.3 The Certificate covers a single blend of clay in a range of colours including orange red, pink, champagne, pearl grey, chocolate brown and ebony. Due to their natural origin, some shade variation between tiles may occur.

Figure 1 System details and tolerances (all dimensions in mm)

for each production batch, the tolerances indicated below must be respected

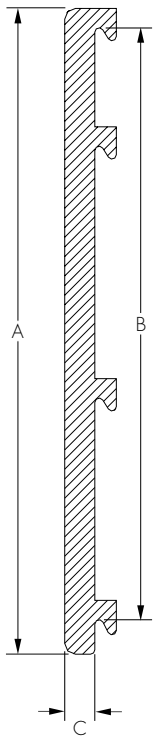

label	dimensions (mm)	batch tolerance (mm)
A <sup>(1)</sup>	298.5 to 301.5	±1.5 mm <sup>(2)</sup>
B	273.5 to 276.5	±1.5 mm <sup>(2)</sup>
C	14	+1 -0.5
D	300 or 605	±2 mm
⊥ perpendicularity	300 or 605	±2 mm
▭ flatness	424 or 675	oop <sup>(3)</sup> 3 mm max
sail effect to point M (I, J and K planar)		oop <sup>(3)</sup> 4 mm max
taper IK or JM (for 300 mm)		oop <sup>(3)</sup> 2.5 mm max
taper IJ or KM (from 300 mm or 605 mm)		oop <sup>(3)</sup> 2.5 mm max (D = 300) oop <sup>(3)</sup> 3.5 mm max (D = 605)

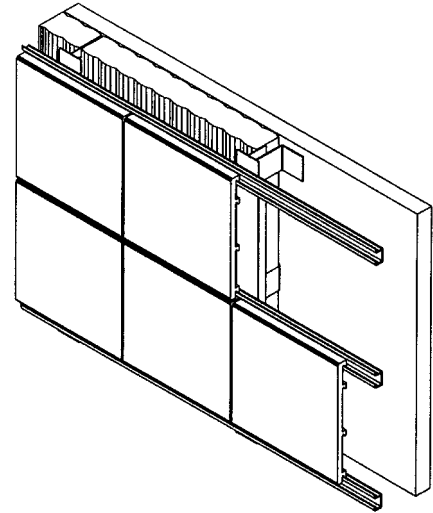

- (1) A is an average dimension for each production batch
- (2) For given production batch, the dimensional tolerance must not exceed 3 mm
- (3) oop = out of plane

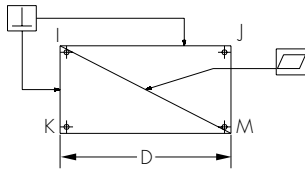

sealant type Sikaflex Pro 11 FC (or similar) at two points

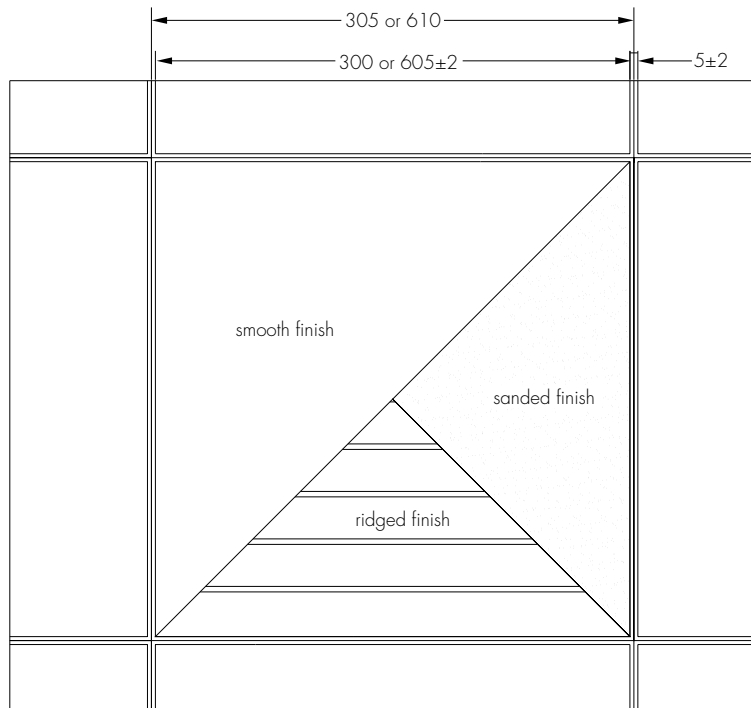
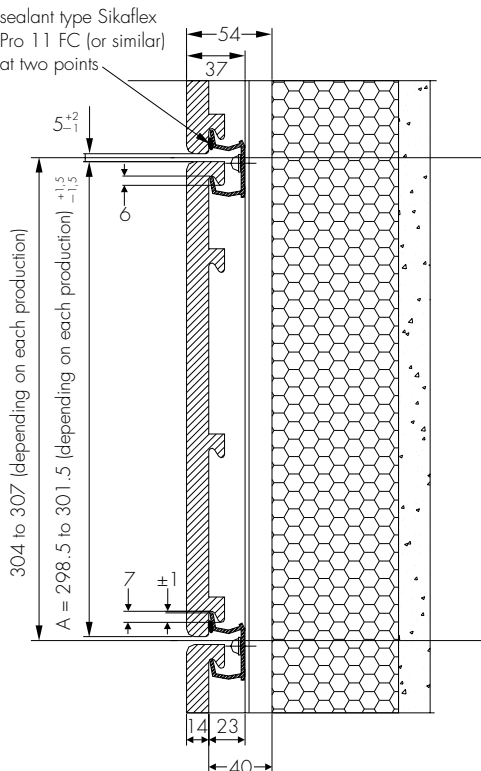

the recommended vertical laying gauge is marked on each pallet. Recommended gauge = A+5 mm (rounded up to the nearest mm)

5.4 The tiles weigh  $32.0 \text{ kgm}^{-2}$  and have a mean water absorption value between 6% and 10% (to BS EN ISO 10545-3 : 1997) and flexural strengths greater than 1050 N (for 300 mm by 300 mm tiles) and 530 N (for 605 mm by 300 mm tiles).

5.5 During production, quality control of the tiles is exercised by self inspections which are regularly monitored by the CSTB.

5.6 The horizontal support rails are of extruded aluminium section, grade 6060 R20, also manufactured by the Certificate holder, and are available in 3 m lengths. Front and back ribs aid drilling and positioning of the rails (see Figure 2).

5.7 An additional intermediate horizontal rail and sub-frame member may be used, as shown in Figure 2, in areas more susceptible to impact damage, eg near ground level.

5.8 There is a 5 mm nominal gap between the tiles both horizontally and vertically.

5.9 The sub-frame and its fixing to the substrate wall is outside the scope of this Certificate as are other miscellaneous construction details.

## 6 Delivery and site handling

6.1 Tiles are delivered to site polythene wrapped and banded on wooden pallets. Pallets should be stored on level ground and not stacked.

6.2 Each pallet of tiles bears a label showing product details such as type, size, nominal thickness, quantity and date of production. Each tile is additionally marked with an identification code including manufacturing references and colour.

6.3 Rails are delivered to site banded onto a wooden pallet with any ancillary items, in separate cardboard boxes.

6.4 Packs of rails should be stacked horizontally on sufficient bearers to prevent distortion, to a maximum height of 1 m. Other components should be stored in a safe weatherproof store.

6.5 Tiles should be handled with care to avoid damage or breakage. Care is required when handling long lengths of rail, particularly at height.

6.6 Care should be exercised, when handling rails, to avoid injury from sharp edges. Protective clothing should be worn and all Health and Safety rules should be observed.

Figure 2 Tile support rail details (all dimensions in mm)

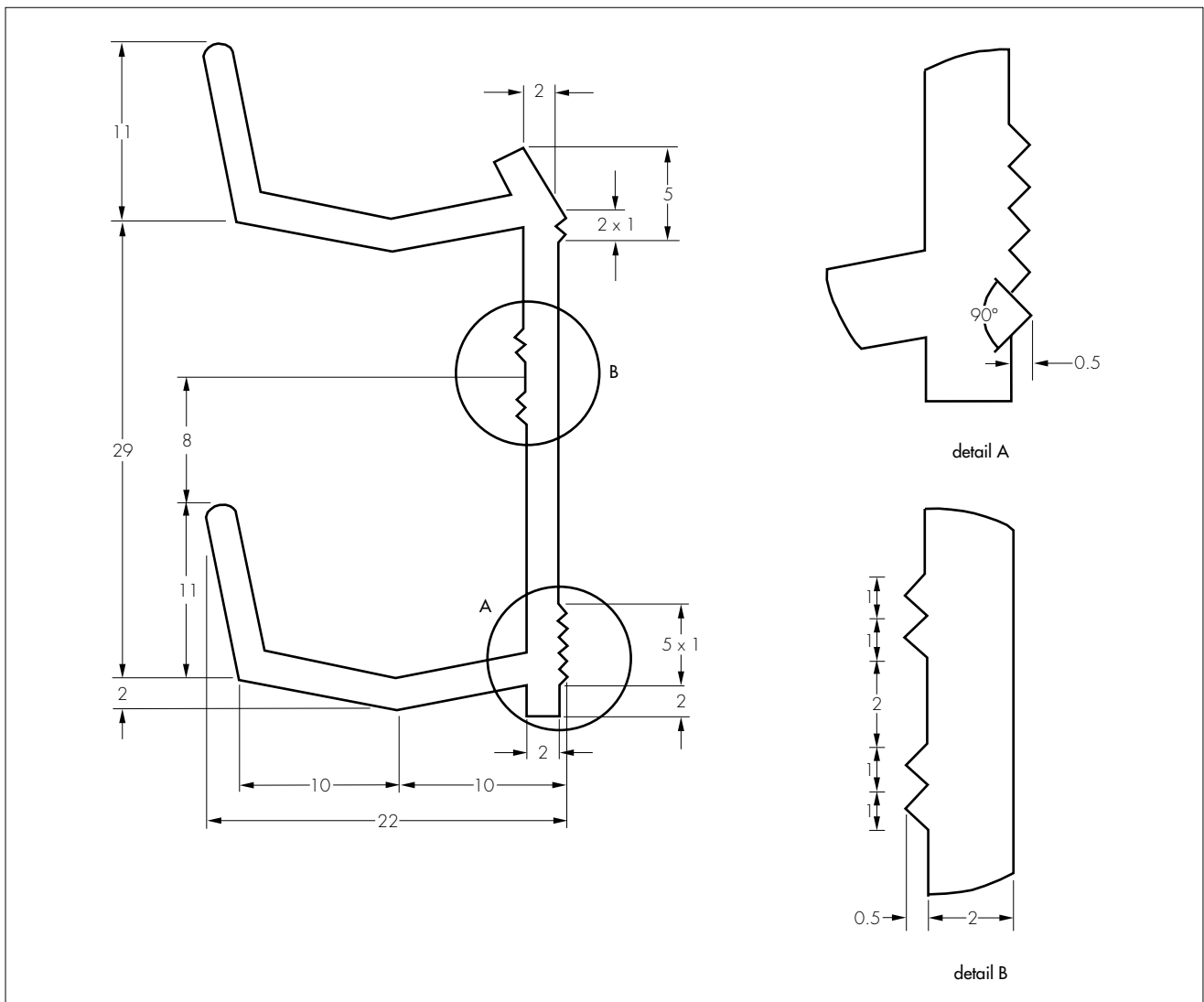

## Design Data

### 7 General

7.1 Ventilation and drainage must be provided behind the cladding, suitable for a back ventilated and drained system. A minimum 40 mm wide air space is required behind the back face of the tiles together with a minimum ventilation area of 100 cm<sup>2</sup> per metre run of cladding. The ventilation openings should be suitably protected, or baffled, to prevent the ingress of birds, vermin and rain.



7.2 The wall and sub-frame to which the cladding is fixed should be structurally sound and constructed in accordance with the requirements of the relevant building regulations and national standards.

7.3 The wall to which the cladding is fixed should be watertight and resistant to the transmission of sound.

7.4 Insulation behind the cladding needs to be suitably fixed to the inner leaf to resist the forces of wind suction incident upon them as a result of the open joints of the cladding. Insulation should be of a rigid type (eg boards). The ventilation pathway behind the cladding must not be allowed to become blocked nor the insulation dislodged where it may be vulnerable to wetting.

7.5 To allow for thermal expansion and water run-off, a gap of 10 mm to 15 mm between the ends of adjacent aluminium support rails should be provided.

7.6 All design aspects of the installation should be checked by a suitably qualified engineer or other appropriately qualified person.

### 8 Practicability of installation

The system is suitable for installation by general building contractors provided they have undergone suitable training by the Certificate holder or their agents.

### 9 Strength and stability

#### Wind loading



9.1 Allowable wind pressure (or suction) values for various support conditions are presented in Table 1.

Table 1 Wind load resistance

Sub-frame spacing (mm)	Horizontal aluminium rails	Allowable wind pressure/suction <sup>(1)</sup> (Pa)
900	2	740
300 and 600	2	1115
900	3	1030
600	3	2208

(1) Derived by applying a safety factor of 4.0 on ultimate values.

9.2 When calculating wind loads, higher pressure coefficients applicable to corners of the building should be used.

9.3 The sub-frame and the support rails should be so designed as to limit mid-span deflections to L/200, and cantilever deflections to L/150.

9.4 A suitably qualified engineer must check the design and installation of the cladding.

9.5 As the cladding is open-jointed, the supporting wall must be able to take the full wind as well as any rocking loads. No contribution from the cladding system should be assumed in this regard.

9.6 Wind loads should be calculated in accordance with BS EN 1991-1-4 : 2005 and BS 6399-2 : 1997.

#### Impact

9.7 In common with all clay-based products, the Zephir tiles are susceptible to damage from hard body impacts. It is recommended that use of the system is restricted to locations where there is some incentive to exercise care and little chance of hard body impacts, such as detailed under categories C, D and F in Table 2 of BS 8200 : 1985.

9.8 The level of safety may be increased to category B by the use of an additional horizontal mid-rail and vertical support stud (see Figure 2).

### 10 Behaviour in relation to fire



10.1 The tiles and aluminium support rails are non-combustible and as such have a Class 0 (National) fire rating.

10.2 If timber studding is used to support the horizontal rails, this will reduce the overall fire performance of the cladding.

10.3 As a consequence of sections 10.1 and 10.2, the system may be regarded as suitable for installations where a Class 1 surface spread of flame is specified in accordance with BS 476-7 : 1997.

10.4 The incorporation of combustible material behind the cladding should be avoided wherever possible; any insulation should be non-combustible.

10.5 Cavity barriers should be incorporated behind the cladding as required under the national Building Regulations, but should not block essential ventilation pathways, for example by use of intumescent cavity barriers (not covered by this Certificate) or overhanging incombustible breaks at each floor level.

### 11 Air and water penetration



11.1 The cladding is not airtight or watertight, but intentionally open-jointed, back ventilated and drained.

11.2 The inner wall supporting the cladding must be watertight, but need not be airtight.

11.3 The minimum gap formed between the back face of the tiles and the substrate wall, or insulation, should be 40 mm.

11.4 To minimise water penetration and risk of damage to the inner wall, the gap between the tiles should be kept at 5 mm throughout.

11.5 The vertical gaps between panels should, as far as possible, coincide with the centre line of vertical studding. This helps to minimise precipitation onto the inner leaf, or insulation, due to wind driven rain.

11.6 In exposed conditions, with frequent wind driven rain, consideration should be given to providing a vapour permeable membrane to protect the inner wall, or insulation, from precipitation. In such cases, the Certificate holder's advice should be sought.

### 12 Maintenance

12.1 The tiles are generally self-cleaning. However, where necessary, the tiles may be cleaned using warm water without additional detergents, solvents or brushes. For the removal of efflorescence, graffiti and other persistent stains, the manufacturer's advice should be sought.

12.2 Damaged tiles should be replaced as soon as practicable following the manufacturer's instructions:

- remove damaged tile and place in container
- cut 4 mm off the bottom rib of the replacement tile, along its entire length, using a circular saw
- clean contact surfaces using a suitable cleaner as recommended by the mastic manufacturer
- apply a continuous bead of mastic, eg Sikaflex IIFC or equivalent, near the cut rib
- hang replacement tiles from top support rail and push them against bottom rail for the mastic bead to make contact (see Figure 2)
- clean up area and dispose of all waste.

12.3 Checks should be carried out periodically to ensure that ventilation and drainage pathways remain clear.

### 13 Durability



13.1 Freeze-thaw tests on similar clay products indicate that there will be no significant change in the physical properties of the tiles on ageing.

13.2 The tiles will have a life equivalent to known, good quality, clay tiles, when used in normal exposure conditions in the United Kingdom (ie in excess of 35 years).

13.3 The aluminium rails and brackets will have a lifetime at least commensurate with the tiles they are supporting.

13.4 After natural weathering, slight change in colour of the tiles may occur. However, this is not likely to be progressive.

### 14 General

14.1 The Zephyr Cladding System must be installed in accordance with the manufacturer's recommendations, the requirements of this Certificate and the specification laid down by the consulting engineer.

14.2 Installers must be trained and approved by the Certificate holder who can provide technical assistance at the design stage and at the start of installation.

14.3 Reference should be made to Figure 2 when reading the procedural details given in section 15.

14.4 If significant colour variations between batches is likely, it may be necessary to mix the tiles from different pallets so as to obtain a uniform shade over the whole façade.

14.5 Due to manufacturing tolerances, some unevenness on the façade surface may occur, but this is not normally excessive or obtrusive. However, to minimise this 'sailing' effect, installation quality should be carefully monitored.

14.6 Vertical support rails and other ancillary components making up the sub-frame are outside the scope of this Certificate.

### 15 Procedure

15.1 A grid layout should be prepared (see Table 2) and the sub-frame installed accordingly (not covered by this Certificate).

Table 2 Grid layout

Cladding (mm)	Grid (mm)
300 x 300	305 x 305
300 x 605	305 x 610

15.2 Using the grid layout in section 15.1, the horizontal rails are fixed to the sub-frame using stainless steel screws of appropriate type and size determined by design. A gauge may be used to facilitate accurate and consistent positioning of the rails.

15.3 Working from the bottom upwards, the tiles are fixed onto the rails using the appropriate back ribs. To prevent rattles and dislodgment of broken tiles, two dabs of mastic should be applied at the bottom rib in contact with the rail (see Figure 1).

15.4 To minimise the risk of precipitation onto the inner wall due to wind driven rain, the following gap and associated tolerances between tiles should be maintained:

- horizontal gap (mm)  $5 + 2/-1$
- vertical gap (mm)  $5 \pm 1.5$ .

## Technical Investigations

The following is a summary of the technical investigations carried out on the Zephir Cladding System.

### 16 Investigations

16.1 Based on the CSTB Technical Approval No 2/02-971 an assessment was made of the system's mechanical resistance, durability, behaviour in relation to fire and practicability of installation.

16.2 An assessment was made of the manufacturing process, associated quality control procedures, and the system's history of use.

16.3 The Certificate holder's technical literature and drawings were examined for any inconsistencies and general content.

## Bibliography

BS 476-7 : 1997 *Fire tests on building materials and structures — Method of test to determine the classification of the surface spread of flame of products*

BS 6399-2 : 1997 *Loading for buildings — Code of practice for wind loads*

BS 8200 : 1985 *Code of practice for design of non-loadbearing external vertical enclosures of buildings*

BS EN 1991-1-4 : 2005 *Eurocode 1 : Actions on structures — Part 1-4: General actions — Wind actions*

BS EN ISO 10545-3 : 1997 *Ceramic tiles — Determination of water absorption, apparent porosity, apparent relative density and bulk density*

### 17 Conditions

17.1 This Certificate:

- (a) relates only to the product that is named, described, installed, used and maintained as set out in this Certificate;
- (b) is granted only to the company, firm or person identified on the front cover — no other company, firm or person may hold or claim any entitlement to this Certificate;
- (c) is valid only within the UK;
- (d) has to be read, considered and used as a whole document — it may be misleading and will be incomplete to be selective;
- (e) is copyright of the BBA;
- (f) is subject to English law.

17.2 References in this Certificate to any Act of Parliament, Regulation made thereunder, Directive or Regulation of the European Union, Statutory Instrument, Code of Practice, British Standard, manufacturers' instructions or similar publication, are references to such publication in the form in which it was current at the date of this Certificate.

17.3 This Certificate will remain valid for an unlimited period provided that the product and the manufacture and/or fabrication including all related and relevant processes thereof:

- (a) are maintained at or above the levels which have been assessed and found to be satisfactory by the BBA;

(b) remain covered by a valid French Agrément; and

(c) are reviewed by the BBA as and when it considers appropriate.

17.4 In granting this Certificate, the BBA is not responsible for:

- (a) the presence or absence of any patent, intellectual property or similar rights subsisting in the product or any other product;
- (b) the right of the Certificate holder to market, supply, install or maintain the product; and
- (c) the actual works in which the product is installed, used and maintained, including the nature, design, methods and workmanship of such works.

17.5 Any recommendations relating to the use or installation of this product which are contained or referred to in this Certificate are the minimum standards required to be met when the product is used. They do not purport in any way to restate the requirements of the Health & Safety at Work etc Act 1974, or of any other statutory, common law or other duty which may exist at the date of this Certificate or in the future; nor is conformity with such recommendations to be taken as satisfying the requirements of the 1974 Act or of any present or future statutory, common law or other duty of care. In granting this Certificate, the BBA does not accept responsibility to any person or body for any loss or damage, including personal injury, arising as a direct or indirect result of the installation and use of this product.



In the opinion of the British Board of Agrément, the Zephir Cladding System is fit for its intended use provided it is installed, used and maintained as set out in this Certificate. Certificate No 06/4298 is accordingly awarded to Terreal.

On behalf of the British Board of Agrément

Date of issue: 26th January 2006

Chief Executive